

Complex permittivity and conductivity of poly aniline at microwave frequencies

S. Biju Kumar^a, Honey Hohn^b, Rani Joseph^b, M. Hajian^c,
L.P. Ligthart^c, K.T. Mathew^{a,*}

^aDepartment of Electronics, Cochin University of Science and Technology, Cochin-682 022, Kerala, India

^bDepartment of Polymer Science and Rubber Technology, Cochin University of Science and Technology, Cochin-682 022, Kerala, India

^cDepartment of Electrical Engineering, Technical University of Delft, 2628 CD Delft, The Netherlands

Abstract

Dielectric properties of polyaniline at different frequencies were studied. Cavity perturbation technique was employed for the study. Poly aniline in the powder and pelletised forms were prepared under different environmental conditions. Different samples of poly aniline exhibit high conductivity. However, the conductivity of samples prepared under different environmental conditions is found to vary. All the samples in the powder form have high conductivity irrespective of the method of preparation. The high conductivity at microwave frequency makes it possible to be used for developing microwave components like filters. © 2001 Elsevier Science Ltd. All rights reserved.

Keywords: Complex permittivity; Perturbation technique; Polyaniline

1. Introduction

All dielectric materials are characterised by their dielectric parameters such as dielectric constant, conductivity and polarisation^{1,2}. These parameters differ with frequency, temperature, pressure etc. Among a large variety of conducting polymers, polyaniline has very important place. It has wide applications in industry, defense and scientific field.^{3,4} Poly aniline samples were prepared at different conditions and each sample was studied.

2. Method of preparation of samples

Chemical oxidative polymerization of aniline was carried out using ammonium per sulphate as initiator in the presence of 1 M HCl and would take about 4 h at room temperature to complete the process. It was then filtered, washed and dried under three different conditions. The different conditions are given below

1. Room temperature drying for 48 h. It was observed that 48 hours drying at room temperature is sufficient to eliminate water content of the

sample and further drying does not change the mass of the sample, showing drying is complete.

2. Oven drying (50–60 °C) under vacuum for 8 h. Very high temperature may affect the quality of polymer. Thus for a safer side, temperature is limited to 60 °C.
3. Vacuum drying for 16 h at room temperature. Vacuum drying for 16 h gives the same amount of drying as at 48 h room temperature drying.

The poly aniline thus prepared is in fine powder form. Measurements were carried out for the samples in powder and pellet forms. Fine powder is pelletised by applying pressure. The density of the pellet is different for different pressure. Diameter of all pellets is 2.5 mm but volume varies slightly.

3. Theory and measurement technique

Dielectric parameters were measured using cavity perturbation technique. Rectangular Cavity operating at S-band (2–4GHz) was used. The block diagram of the experimental arrangement is shown in Fig. 1 and the schematic diagram of the rectangular cavity is shown in Fig. 2. Pelletised samples can be inserted into the cavity through the opening as shown in the figure. Powder samples can

* Corresponding author. Tel.: +91-484-532161; fax: +91-484-532800.

E-mail address: mathew@doe.cusat.edu (K.T. Mathew).

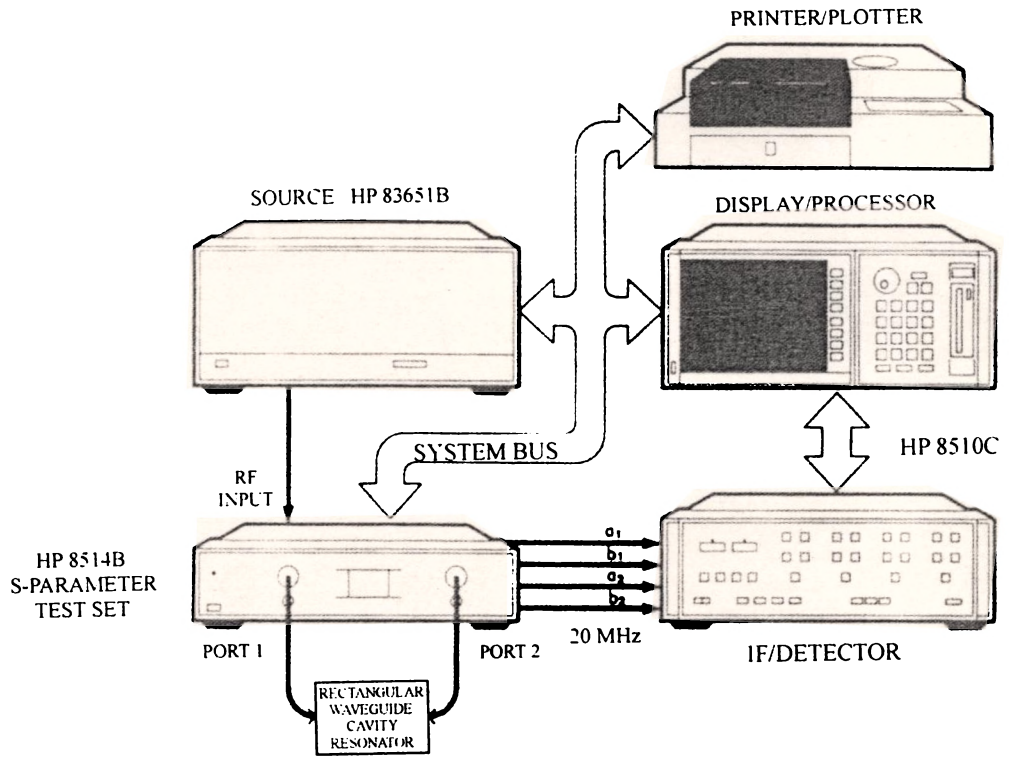

Fig. 1. Block diagram of the experimental set-up.

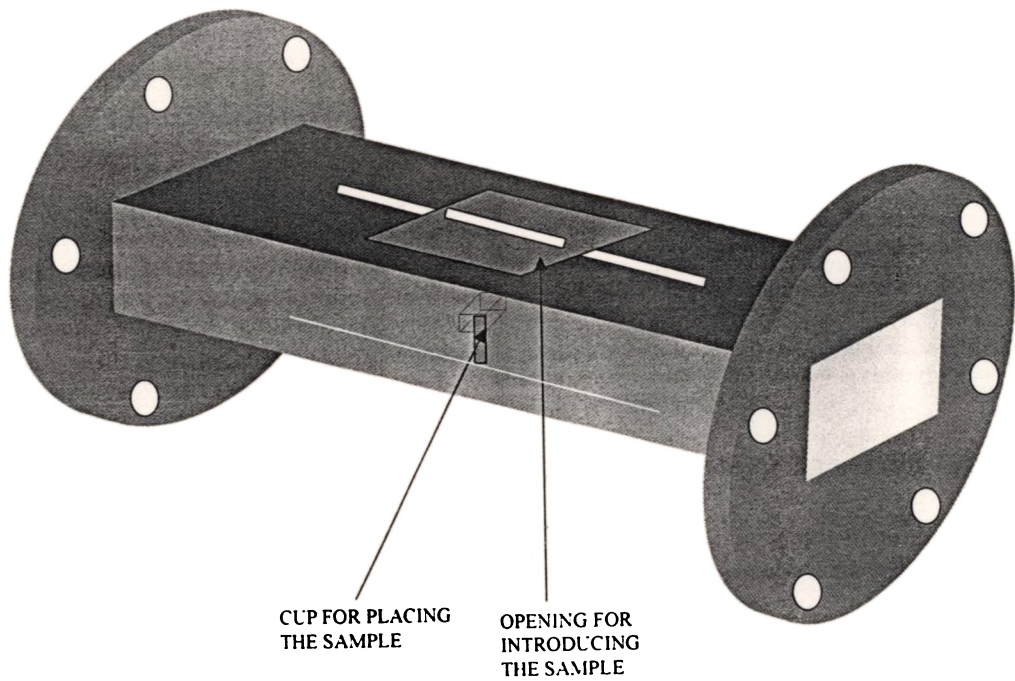

Fig. 2. Schematic diagram of the rectangular cavity resonator.

also be studied using the same cavity. For the complex permittivity measurement of powder, it is taken in the capillary tube of low loss silica of small bore (less than 0.5 mm radius) and wall thickness. The weight fraction of the powder samples is almost the same in all cases.

The determination of the complex permittivity and conductivity is based on the theory of perturbation. When the sample is introduced into the cavity, the relative complex frequency shift of the resonator is given by Waldron⁵ as

$$\frac{d\Omega}{\Omega} \approx \frac{(\bar{\epsilon}_r - 1)\epsilon_0 \int_{V_s} E \cdot E_0^* dV + (\bar{\mu}_r - 1)\mu_0 \int_{V_c} H \cdot H_0^* dV}{\int_{V_c} (D_0 \cdot E_0^* + B_0 \cdot H_0^*) dV} \quad (1)$$

E_0 is the electric field in the unperturbed cavity, E is the electric field in the perturbed cavity and D is the displacement current density. H_0 , H and B are the respective magnetic quantities. $\bar{\epsilon}_r$ is the relative complex permittivity of the sample. But $\bar{\epsilon}_r = \epsilon_r' - j\epsilon_r''$ where ϵ_r' is the real part of the complex permittivity and ϵ_r'' is the imaginary part of the complex permittivity. μ is the magnetic parameter.

The numerator of Eq. (1) represents the total energy stored in the sample and the denominator represents the total energy stored in the cavity. When a dielectric material is introduced in a cavity resonator at the position of maximum electric field, the contribution of magnetic field for the perturbation is minimum. The field perturbation due to the introduction of dielectric sample at the position of maximum electric field is related by Kupfer et al.⁶

$$\frac{d\Omega}{\Omega} \approx \frac{(\bar{\epsilon}_r - 1) \int_{V_s} E \cdot E_{0\max}^* dV}{2 \int_{V_c} |E_0|^2 dV} \quad (2)$$

where $d\Omega$ is the complex frequency shift. V_s and V_c are the volumes of the sample and the cavity resonator respectively. Complex frequency shift is related to the quality factor, Q as

$$\frac{d\Omega}{\Omega} = \frac{d\omega}{\omega} + \frac{j}{2} \left(\frac{1}{Q_s} - \frac{1}{Q_t} \right) \quad (3)$$

Q_s and Q_t are the quality factors of cavity resonator with and without the sample.

Quality factor Q is given by, $Q = \frac{f}{\Delta f}$ where f is the resonant frequency and Δf is the corresponding 3 dB bandwidth.

For small sample, we assume that $E = E_0$ which is one of the assumptions taken in the theory of perturbation. For dominant TE_{10p} mode in rectangular wave guide,

$$E_0 = E_{0\max} \sin \frac{\pi x}{a} \sin \frac{p\pi z}{d}, \quad p = 1, 2, 3 \dots \quad (4)$$

$E_{0\max}$ is the peak value of E_0 , a is the broader dimension and d the length of the waveguide cavity resonator, respectively.

From Eqs. (2)–(4), we get

$$\epsilon_r' - 1 = \frac{f_t - f_s}{2f_s} \left(\frac{V_c}{V_s} \right) \quad (5)$$

$$\epsilon_r'' = \frac{V_c}{4V_s} \left(\frac{Q_t - Q_s}{Q_t Q_s} \right) \quad (6)$$

The real part, ϵ_r' of the complex permittivity is usually known as dielectric constant. The imaginary part, ϵ_r'' of the complex permittivity is associated with dielectric loss of the material.

For a dielectric material having non-zero conductivity, we have Maxwell's curl equation

$$\begin{aligned} \nabla \times H &= (\sigma + j\omega\epsilon)E \\ &= (\sigma + \omega\epsilon'')E + j\omega\epsilon'E \end{aligned}$$

The loss tangent

$$\tan \delta = \frac{\sigma + \omega\epsilon''}{\omega\epsilon'}$$

Here $\sigma + \omega\epsilon''$ is the effective conductivity of the medium.

When σ is very small, the effective conductivity is reduced to

$$\sigma_e = \omega\epsilon'' = 2\pi f\epsilon_0\epsilon_r'' \quad (7)$$

4. Results and discussion

It is observed that the polyaniline exhibits high conductivity. However the complex permittivity and conductivity of the samples prepared at different environmental conditions vary. The samples in the powder form have greater conductivity than that in the pellet form irrespective of the method of preparation. The conductivity measurement of poly aniline at static electric field indicates that it has the property of insulator. All measurements were done at 25 °C. The results are shown in Table 1. An exhaustive study of the complex permittivity and conductivity of the poly aniline in the powder and pellet forms shows interesting results. The conductivity is less than that of a conductor but greater than that of an insulator at microwave frequencies. Because of this property, poly aniline can be used to construct microwave components like filters. An anomaly observed in the dielectric behaviour of poly aniline is that its conductivity drops to a very low value when it is pelletised from the powder form. ϵ'' And hence σ_e is small means that $(Q_t - Q_s)$ is very small [Eq. (6)]. Due to experimental

Table 1
Dielectric parameters of different samples of poly aniline

	Sample	Frequency (GHz)	ϵ'	ϵ''	σ_c (S/m)
Room temperature drying for 48 h	Powder	2.43	13.04	9.84	1.336
	Powder	2.97	12.53	8.65	1.43
	Pellet	2.86	6.88	0.0059	0.00094
	Pellet	3.9	5.68	0.0953	0.0207
Oven drying 50–60 °C for 8 h under vacuum	Powder	2.43	10.03	2.18	0.2958
	Powder	2.97	9.70	2.05	0.338
	Pellet	2.86	7.27	−0.1558	−0.0249
	Pellet	3.9	8.86	0.0087	0.0019
Vacuum drying for 16 h at room temperature	Powder	2.68	13.73	6.66	0.9939
	Powder	3.97	9.72	4.97	1.098
	Pellet	2.86	11.18	0.941	0.1496
	Pellet	3.36	11.52	−0.4425	−0.0825

error, sometimes, Q_2 may be slightly greater than Q_1 and hence the negative values for ϵ'' and σ_c . The effect of external field on the dielectric behaviour of poly aniline at microwave frequencies is under investigation.

References

1. Martinelli, M., Rolla, P. A. and Tombari, E., A method for dielectric loss measurements by a microwave cavity in fixed resonance condition., *IEEE Trans. Microwave Theory and Techniques*, 1985, **33**, 779–783.
2. Xu, Y., Ghannouchi, F. M. and Bosisio, R. C., Theoretical and experimental study of measurement of microwave permittivity using open-ended elliptical coaxial line probes. *IEEE Trans. Microwave Theory and Techniques*, 1992, **40**, 143–150.
3. Lee, C. Y., Song, H. G., Jang, K. S., Oh, E. J., Epstein, A. J. and Joo, J., Electromagnetic interference shielding efficiency of poly-aniline mixtures and multilayer films. *Synthetic Metals*, 1999, **102**, 1346–1349.
4. Joo, J., MacDiarmid, A. G. and Epstein, A. J., Control of dielectric response of polyanilines: applications to EMI Shielding. *Proc. Annual Technical Conference of Soc. of Plastics Engineers*, Boston, MA, 7–11 May 1995, **2**, pp. 1672–1677.
5. Waldron, R. A., Perturbation theory of resonant cavities. In *Proceedings of IEE.*, 1960, **107C**, pp. 272–274.
6. Kupfer, K., Kraszewski, A. and Knöchel, R., *Sensors Update Vol. 7- RF & Microwave Sensing of Moist Materials, Food and other Dielectrics*. Wiley-VCH, Germany, 2000, pp. 186–209.